

# Industrial Vehicles

# Vehículos Industriales



Norlift of Oregon, Inc.

**Welcome!**

**¡Bienvenidos!**

**The reason**

**La razón**

**The goal**

**La meta**



Norlift of Oregon, Inc.

# Basic parts

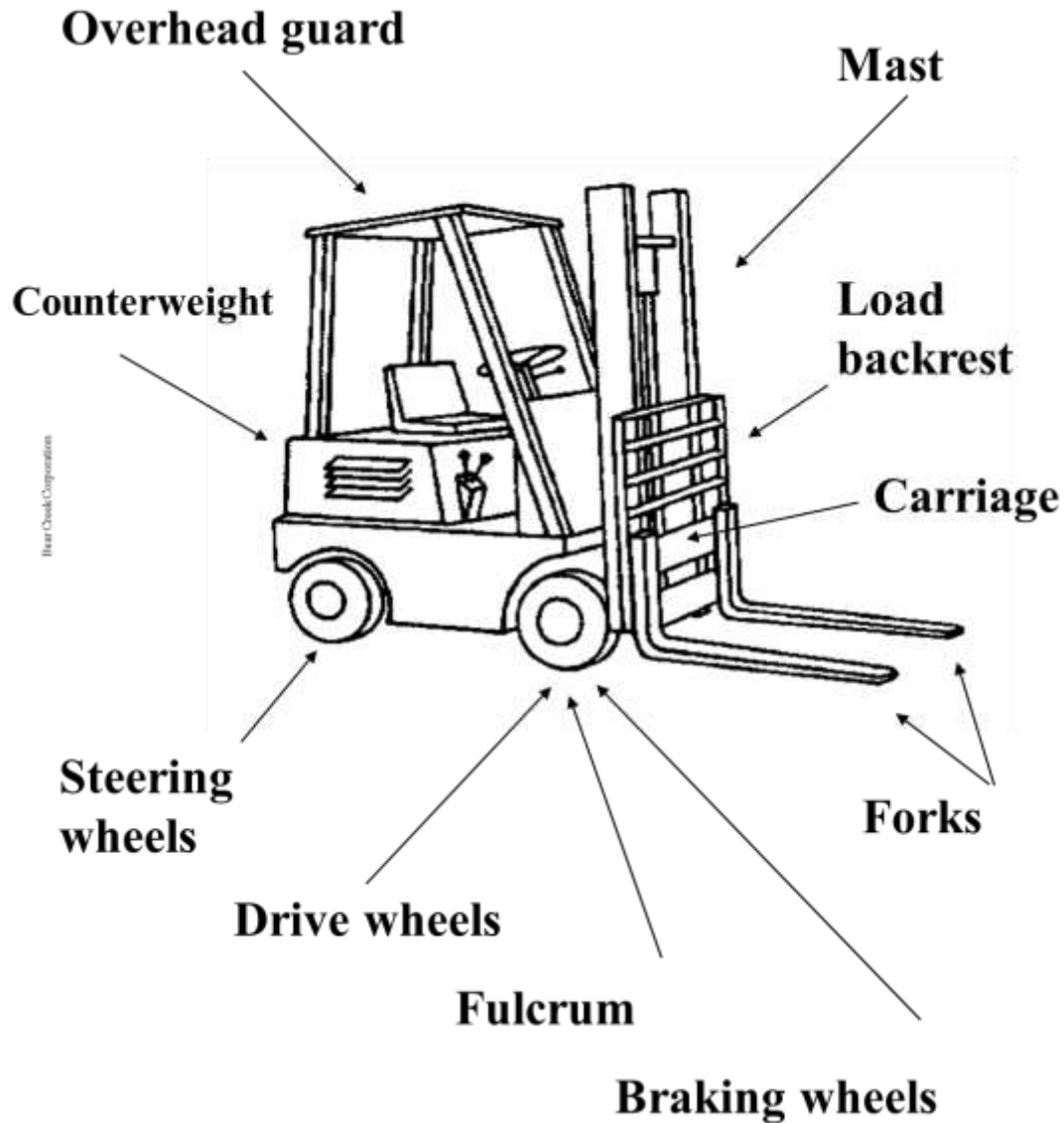

# Componentes básicos

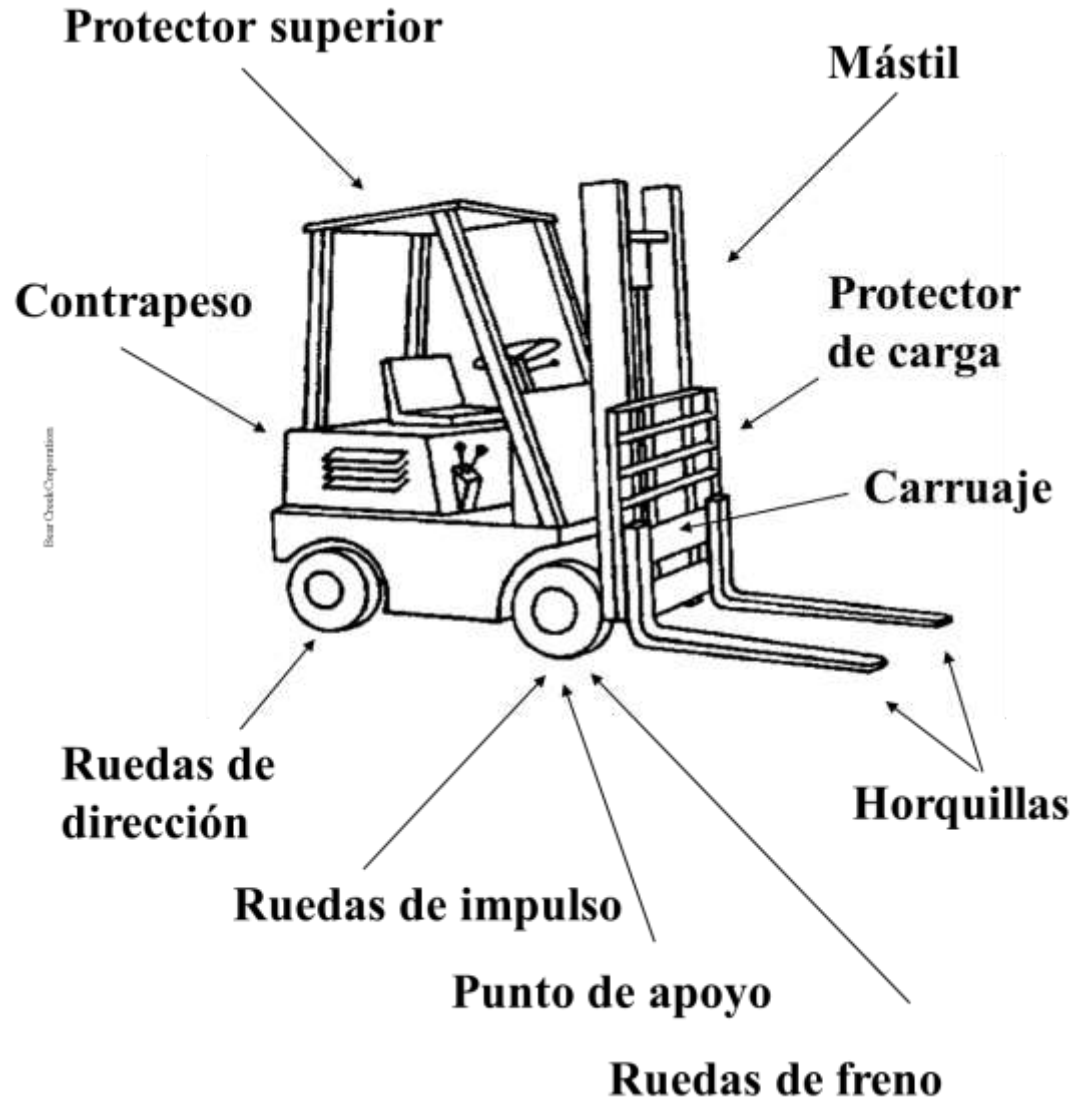

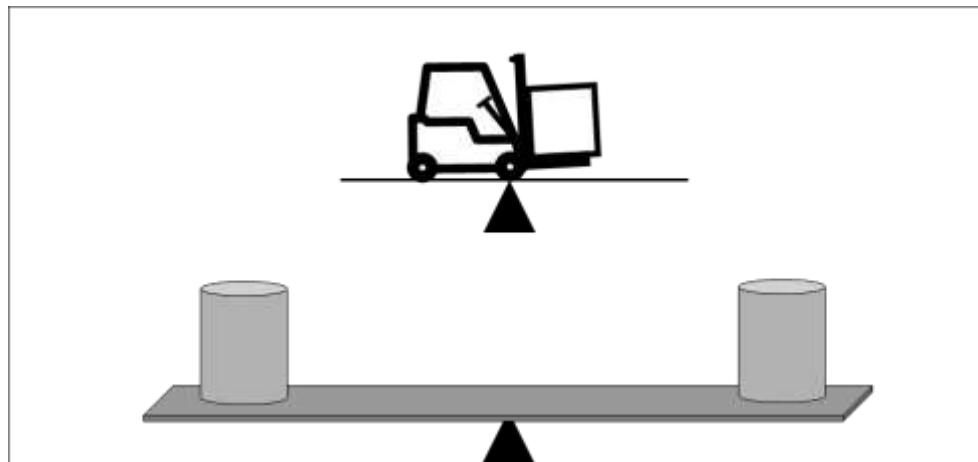

**FULCRUM      FULCRO**

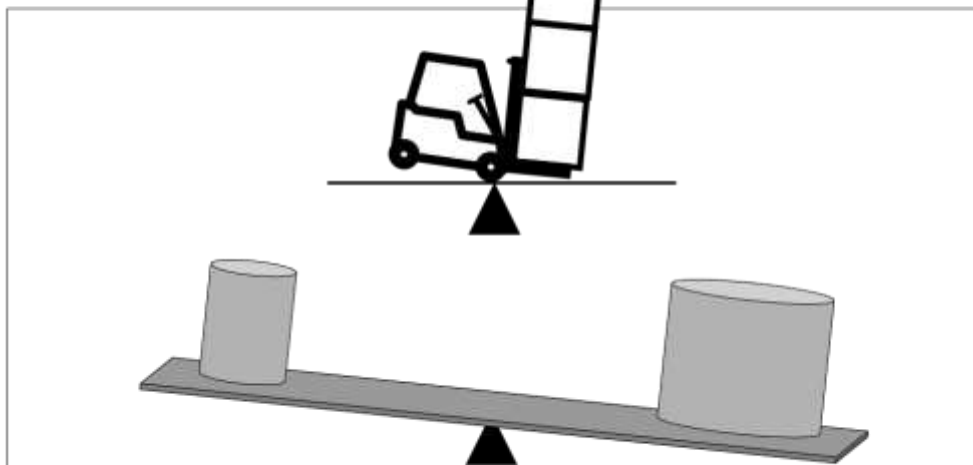

**FULCRUM      FULCRO**

**Balance**

**Equilibrio**

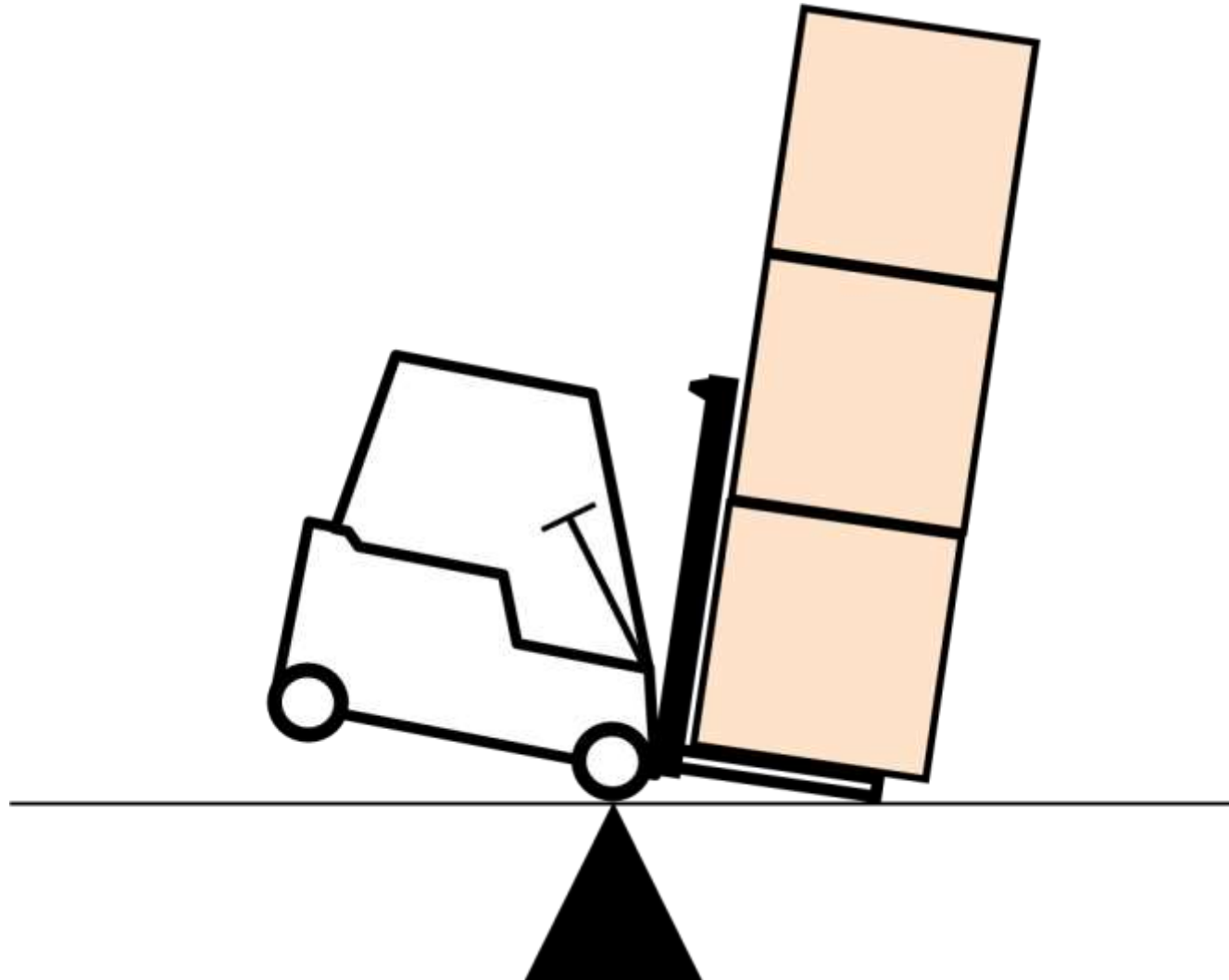

**Balance**

**Equilibrio**



# Center of Gravity

# Centro de Gravedad

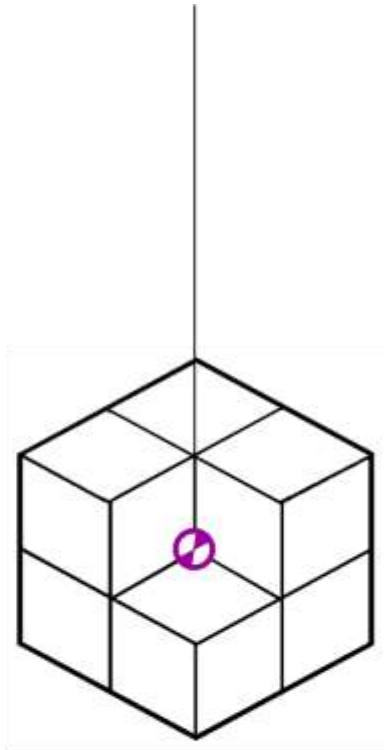



# Center of Gravity

# Centro de Gravedad

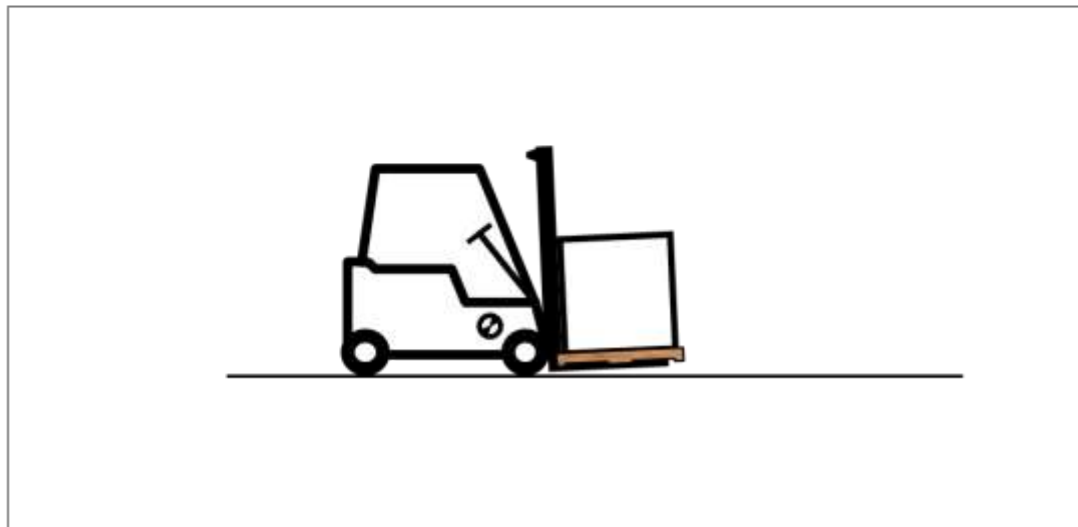
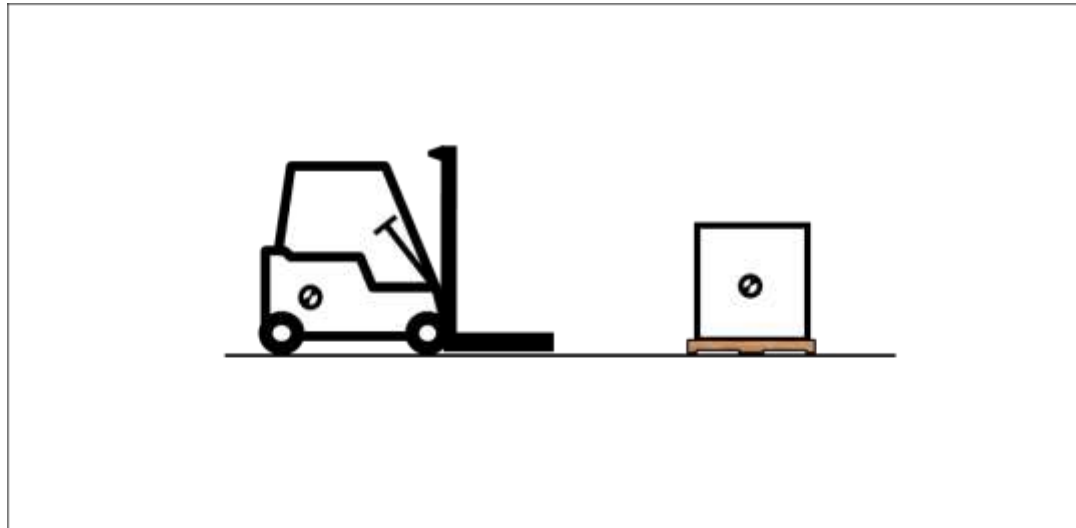

# Center of Gravity

# Centro de Gravedad

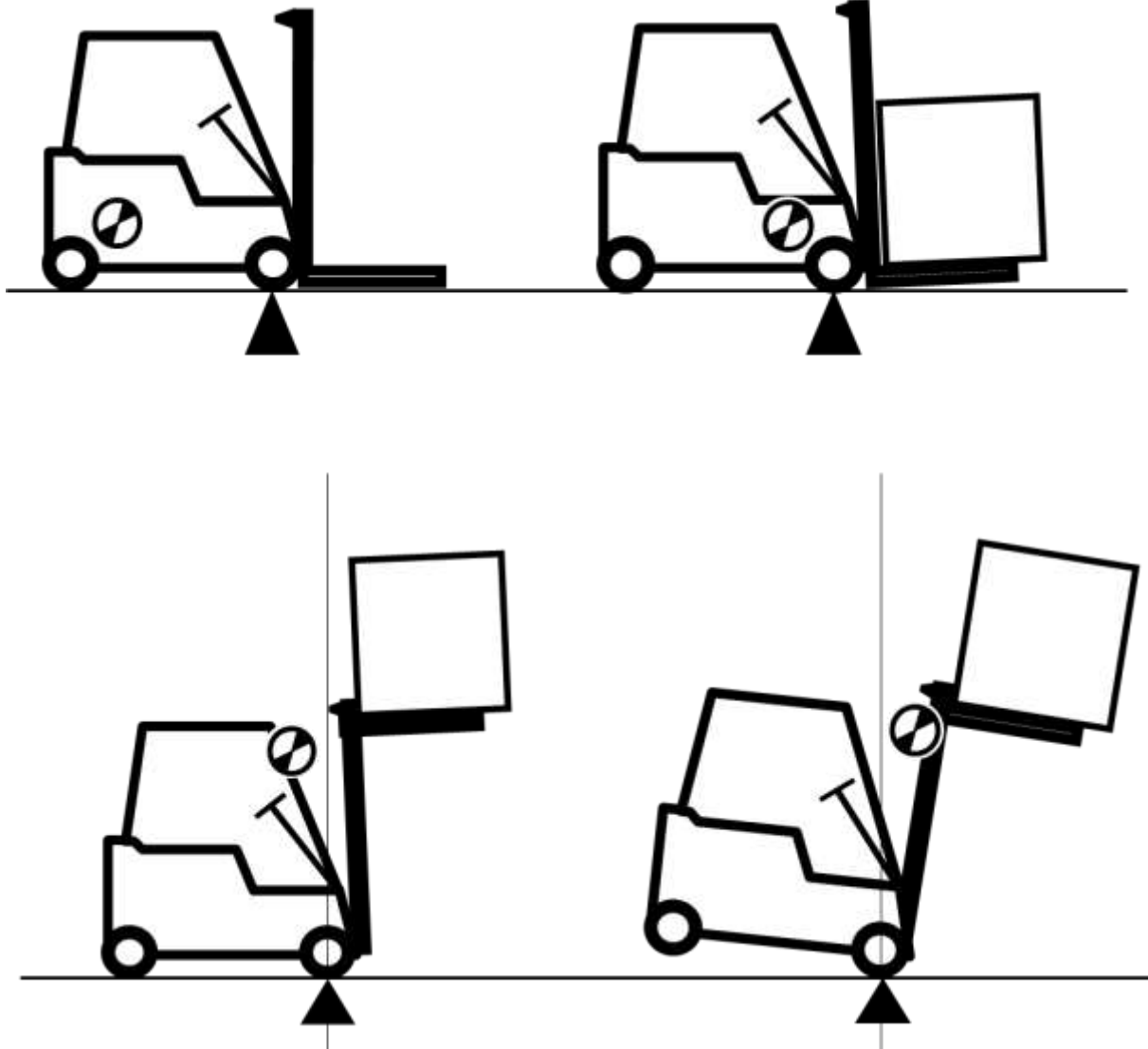

**Center of Gravity**

**Centro de Gravedad**

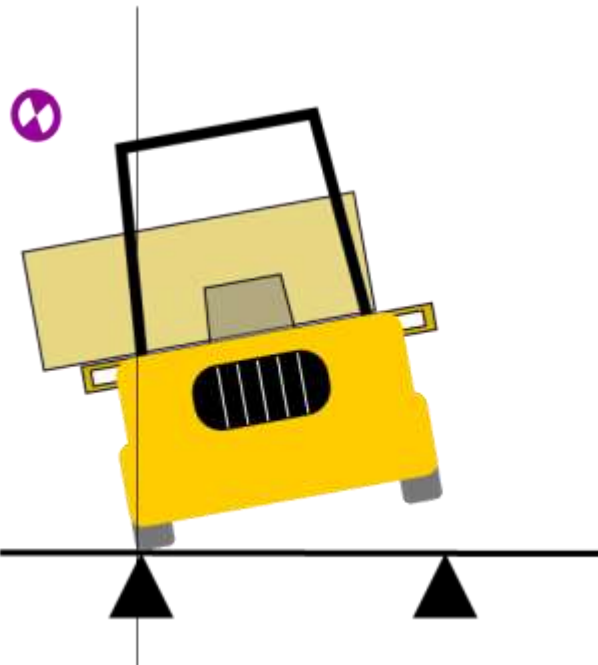
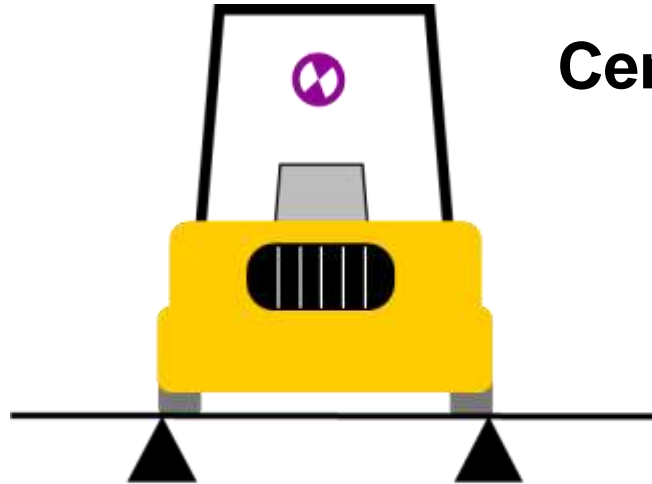

# Stability

# Estabilidad

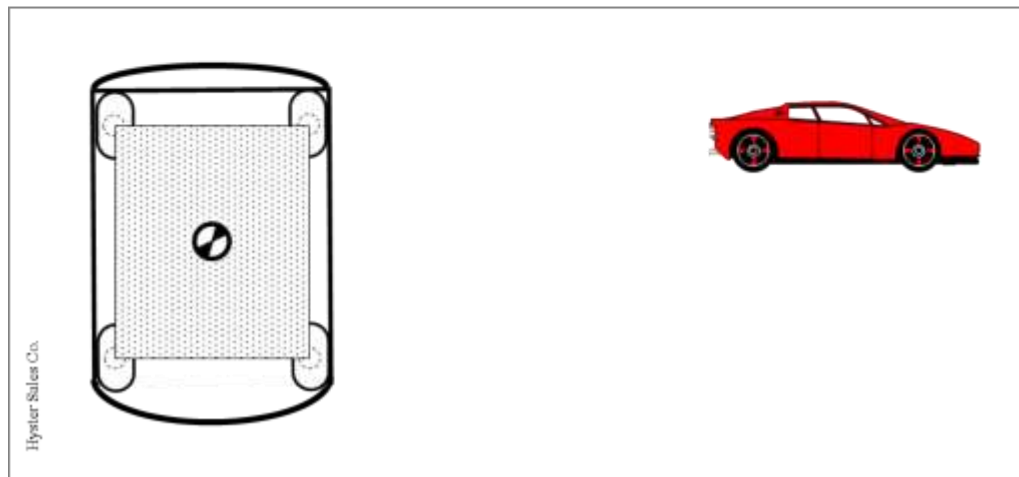
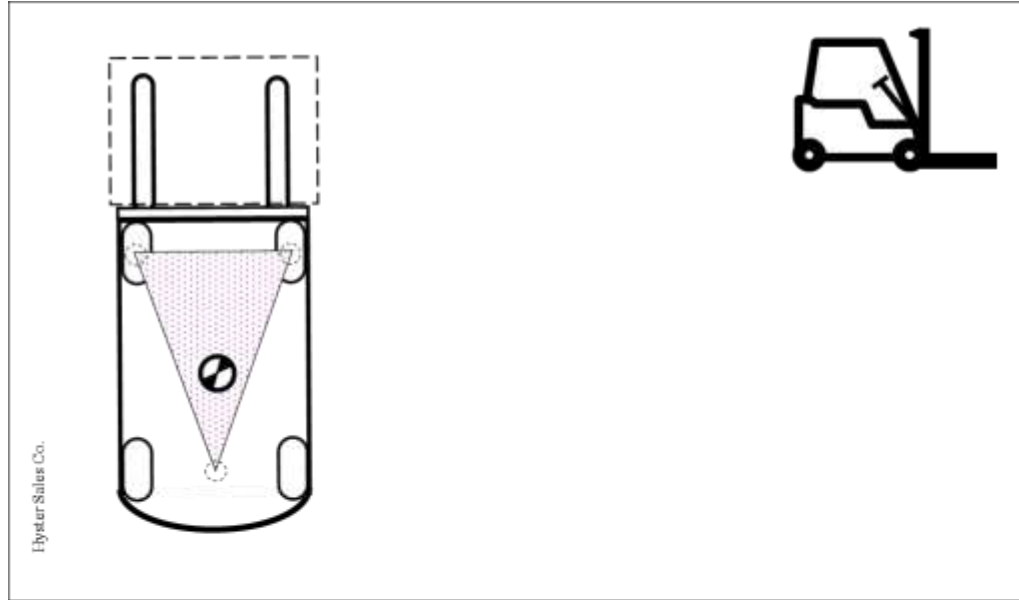

# Stability

# Estabilidad

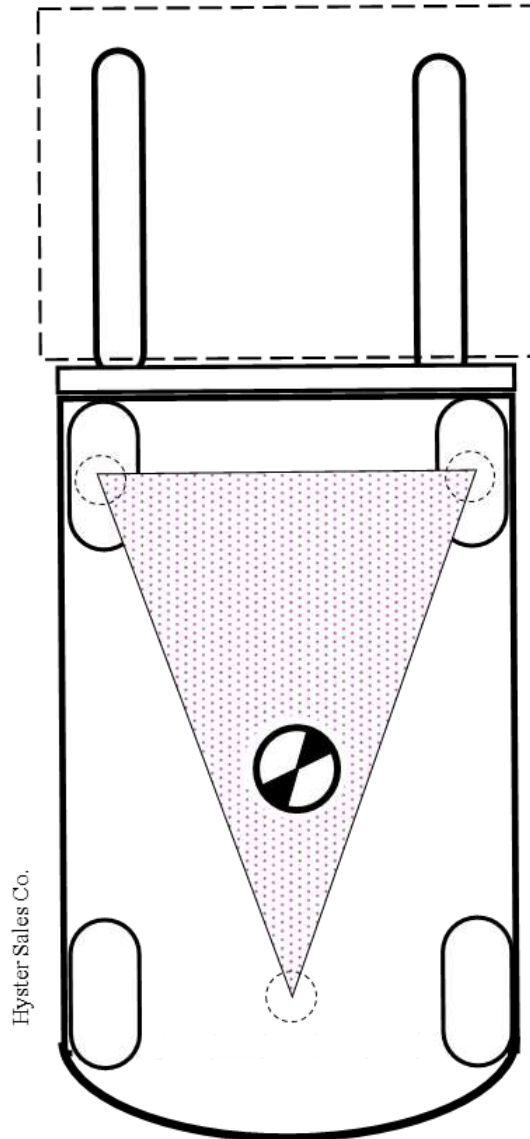

# Stability



# Estabilidad

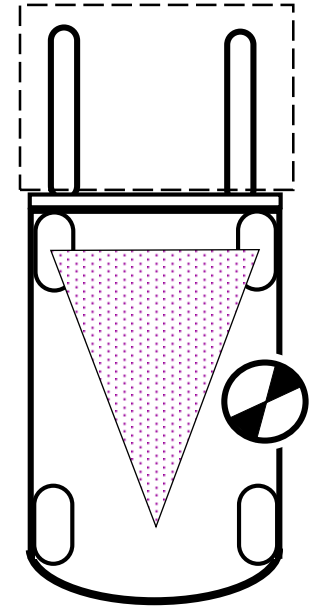
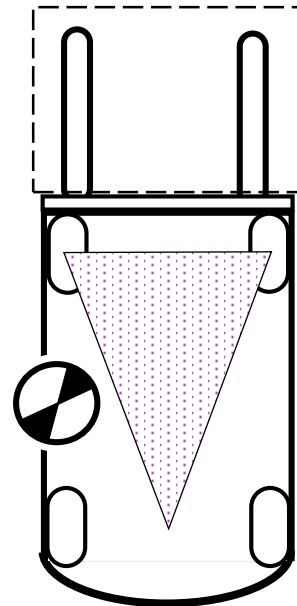

# Stability

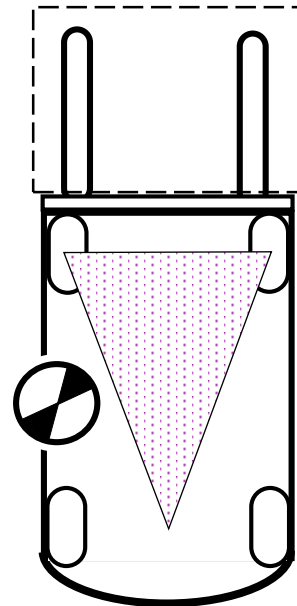

# Estabilidad

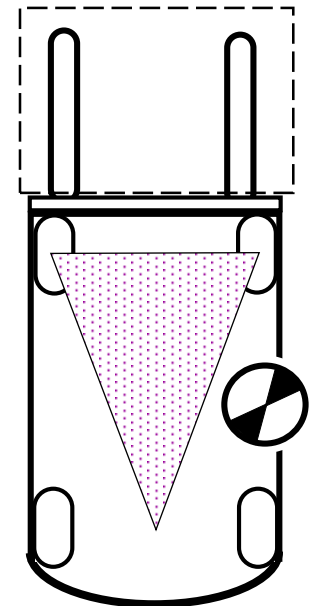

# Stability



# Estabilidad

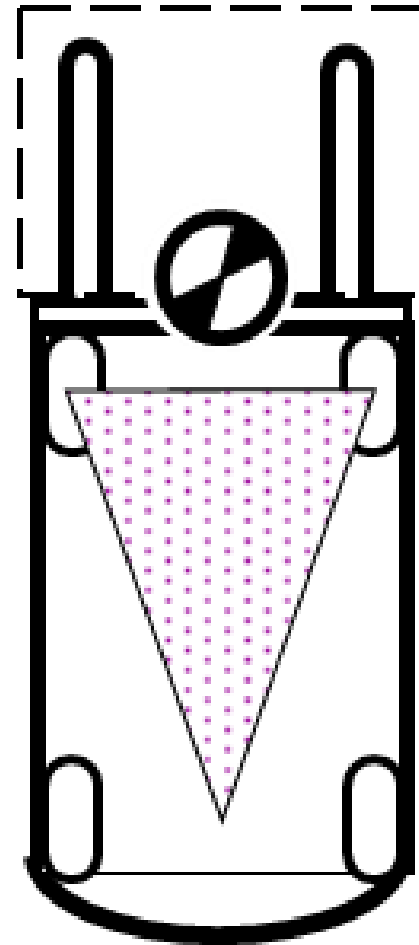



# Stability

# Estabilidad

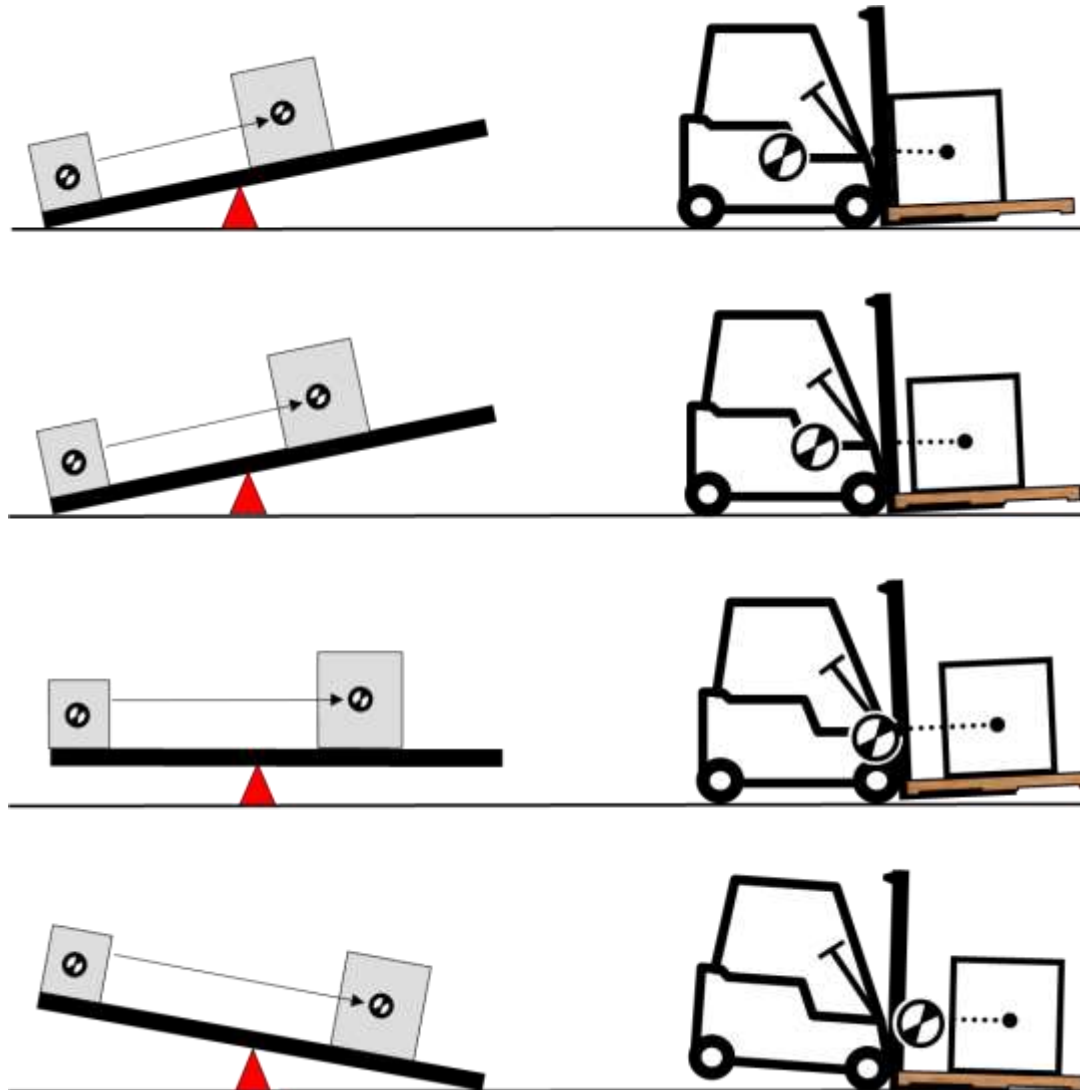

# Stability

# Estabilidad

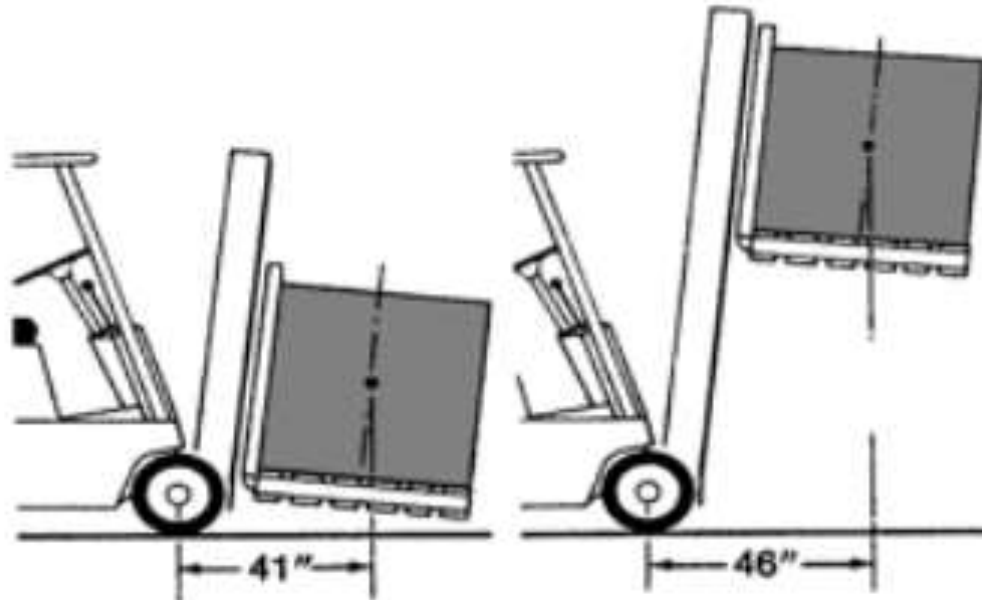
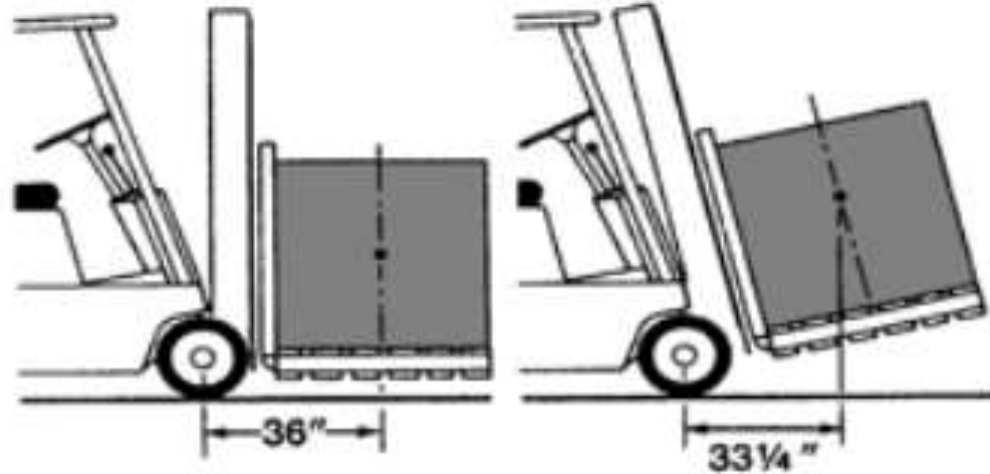

# Data Plate

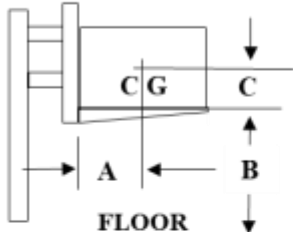
|   |  |          |          |             |
|---|--|----------|----------|-------------|
| <b>MODEL NO.</b>  |  |          |          | <b>TYPE</b> |
| <b>SERIAL NO.</b>   |  |          |          |             |
| <b>ACCESSORIES</b>  |  |          |          |             |
|  | <b>CAPACITY WITH ATTACHED LISTED ABOVE OR<br/>WITH FORKS - UPRIGHTS VERTICLE</b> |          |          |             |
|   | <b>LBS</b>   | <b>A</b> | <b>B</b> | <b>C</b>    |
|   |  |          |          |             |
|   |  |          |          |             |
|   |  |          |          |             |
|   | <b>LESS BATT ELECTRICS</b>   |          |          |             |
|   | <b>WITH MAX. BATT WT.</b>  |          |          |             |
|   | <b>MAX</b>   |          |          | <b>MIN</b>  |
|   | <b>AH</b>  |          |          | <b>NO</b>   |
|   | <b>LBS</b>   |          |          | <b>VOLT</b> |

**APPROX. WT. ALL TRUCKS**  
**APPROX. WT. ELECTRICS ONLY**  
**BATTERY WT. BATTERY CAPACITY**

**FOR OTHER CAPACITIES - CONSULT MANUFACTURER  
 AS RELEASED FROM FACTORY THIS TRUCK MEETS THE  
 DESIGN SPECIFICATIONS ESTABLISHED IN AMERICA  
 NATIONAL STANDARD FOR POWERED INDUSTRIAL TRUCKS  
 PART II, ANSI B56 1-1969 PART NO. 2315709**

Spanish  
Español →



# Placa de Carga

|   |          |             |             |
|---|----------|-------------|-------------|
| <b>MODELO NO.</b>   |          | <b>TIPO</b> |             |
| <b>NO. DE SERIE</b>   |          |             |             |
| <b>ACCESORIOS</b>   |          |             |             |
|   |          |             |             |
| PESO APROXIMADO<br>TODOS VEHICULOS<br>PESO APROXIMADO<br>ELECTRICOS SOLOS                       |          |             |             |
| <b>PESO BATERIA</b>   |          |             |             |
| <b>BATERIA</b>  |          |             |             |
| <b>CAPACIDAD</b>  |          |             |             |
| CAPACIDAD CON ACCESORIOS INDICADOS<br>ANTERIORMENTE O CON HORQUILLAS -<br>MONTANTES EN VERTICAL |          |             |             |
| <b>LIBRAS</b>   | <b>A</b> | <b>B</b>    | <b>C</b>    |
|   |          |             |             |
|   |          |             |             |
|   |          |             |             |
| <b>MENOS BATERIA Y ELECTRICOS</b>   |          |             |             |
| <b>CON PESO MAXIMO BATERIA</b>  |          |             |             |
| <b>MAX</b>  |          |             | <b>MIN</b>  |
| <b>AH</b>   |          |             | <b>NO</b>   |
| <b>LIBRAS</b>   |          |             | <b>VOLT</b> |

**PARA OTRAS CAPACIDADES - LLAME AL FABRICANTE  
 TAL COMO SE LIBRA DE LA FABRICA, ESTE VEHICULO SE  
 ACATA A LAS ESPECIFICACIONES DE DISEÑO ESTABLECIDO  
 EN LOS ESTADOS UNIDOS DE AMERICA  
 ESTANDAR NACIONAL PARA VEHICULOS MOTORIZADOS  
 INDUSTRIALES  
 PARTE II, ANSI B56 1-1969 PARTE NO. 2315709**



# Operator seat restraint

# Retención del operador



Norlift of Oregon, Inc.

# Safe Operation

# Operación Segura

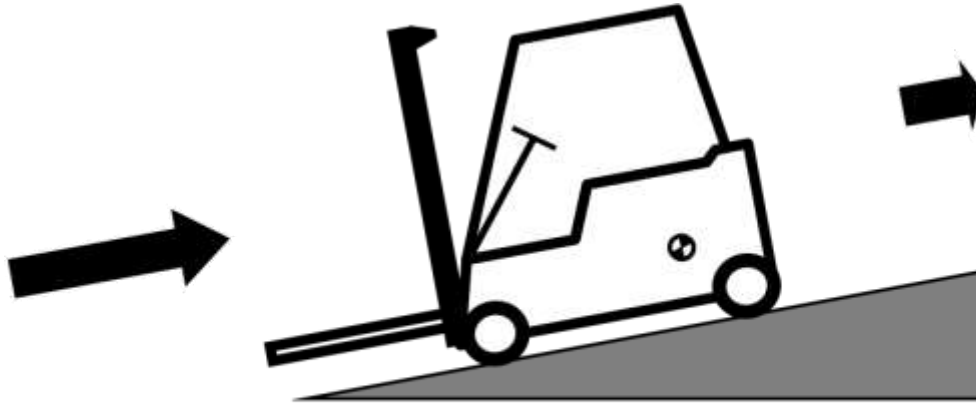

**Going up  
or Down**

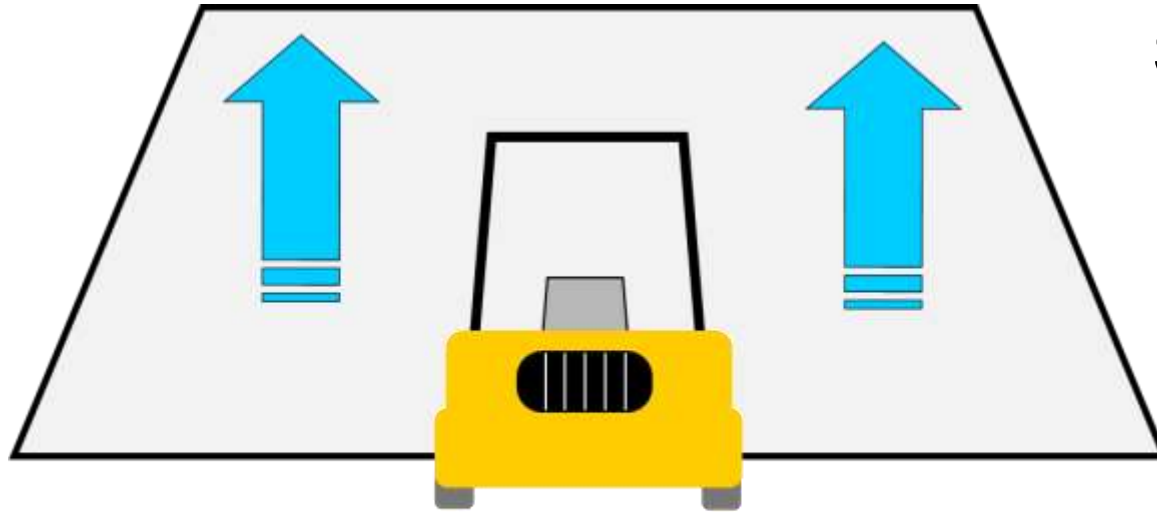

**Subiendo o  
Bajando**



**Danger! ¡Peligro!**

# Lifting the Load

# Levantando la Carga



Earthworks Training and Assessment Services



**Traveling**

**Circulando**



# Traveling

# Circulando



**Placing  
and  
stacking  
a load**



**Acomodando  
y apilando la  
carga**

# Safe Operation

# Operación Segura



Norlift of Oregon, Inc.



# Safe Operation

# Operación Segura



**Lifting workers**

**Elevando a Trabajadores**



Cotterman Co.

**Danger?**

**¿Peligro?**



**Danger?**



**¿Peligro?**



**Danger?**

**¿Peligro?**



*Thank you! ¡Gracias!*