

Scaffolds

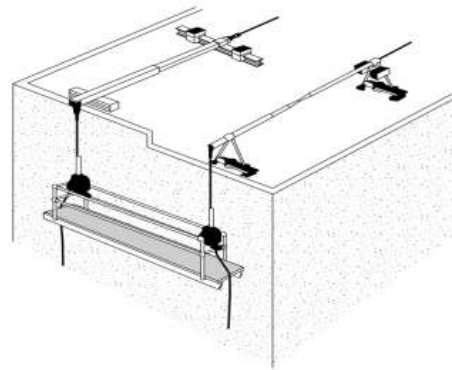

Andamios

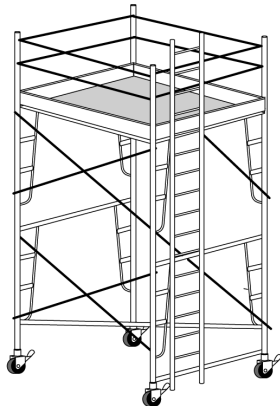
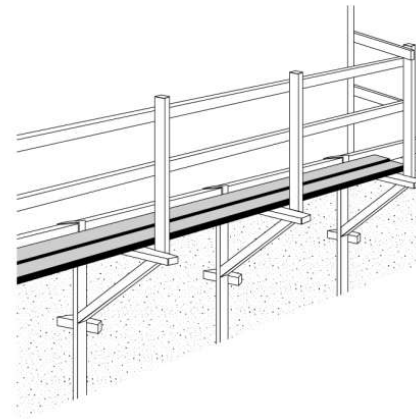

Welcome!

¡Bienvenidos!

The reason

La razón

The goal

La meta

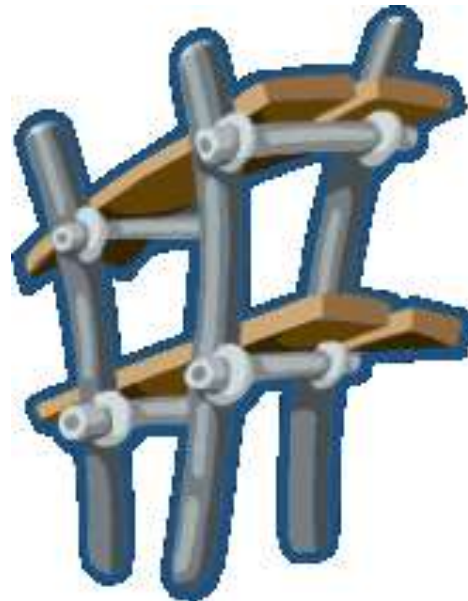

Two main kinds

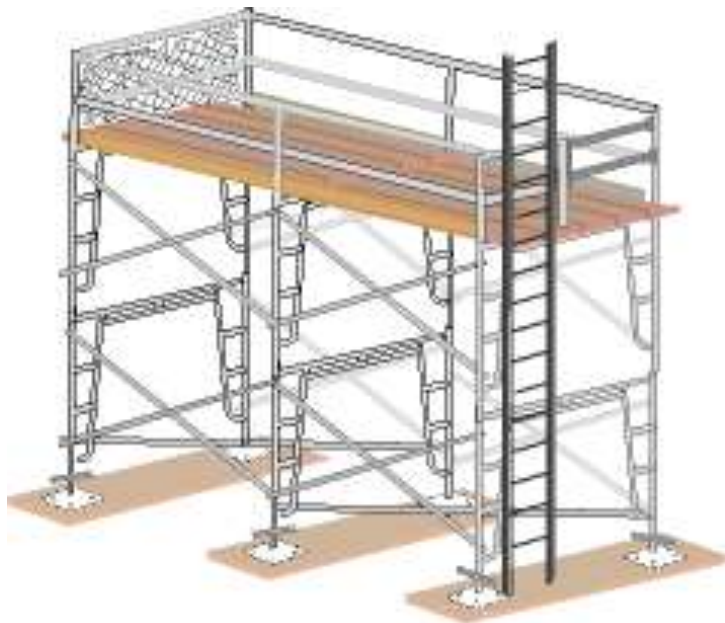

Dos tipos principales

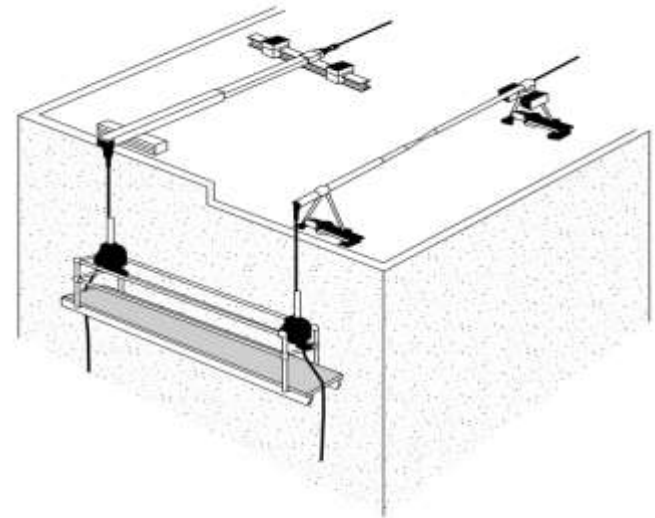

What you need to know

- **Base**
- **Support structure**
- **Access**
- **Fall protection**
- **Platform**
- **Electrical hazards**
- **Falling objects**

Lo que necesita saber

- **La base**
- **El soporte de la estructura**
- **El acceso**
- **La protección contra caídas**
- **La plataforma**
- **Los peligros eléctricos**
- **Objetos en caída**

Scaffold hazards



Riesgos de andamios

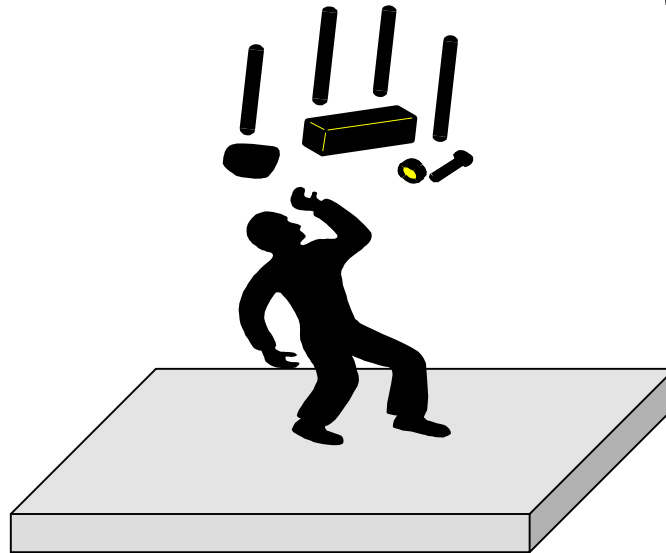

The base



La base



The base

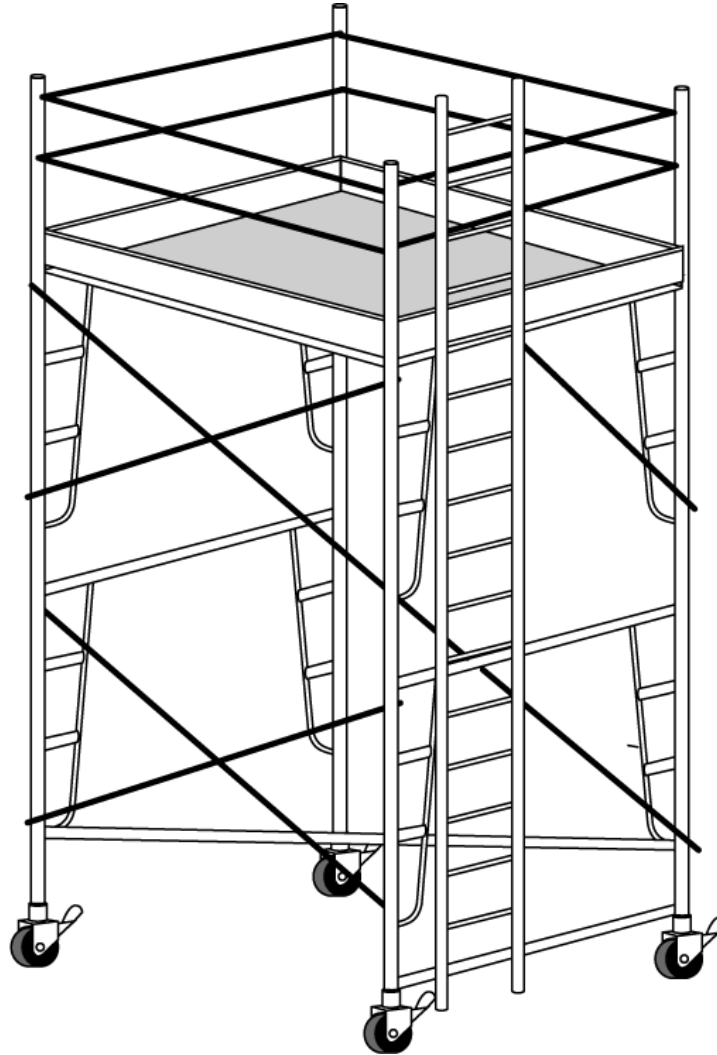

La base



Support



Soporte



Support



Soporte



Access

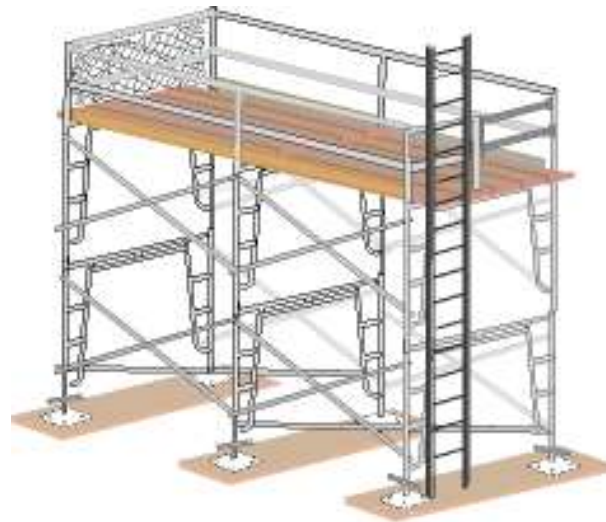

Acceso

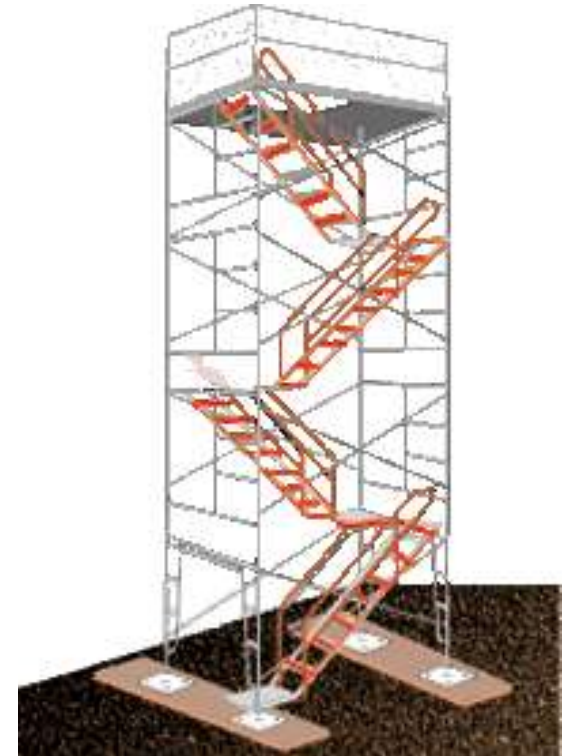

Fall protection

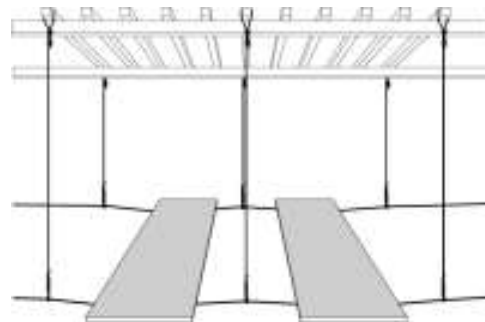
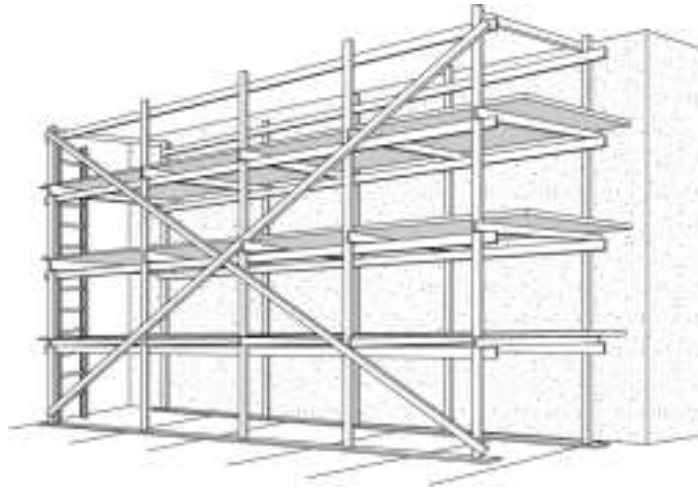

Protección contra caídas

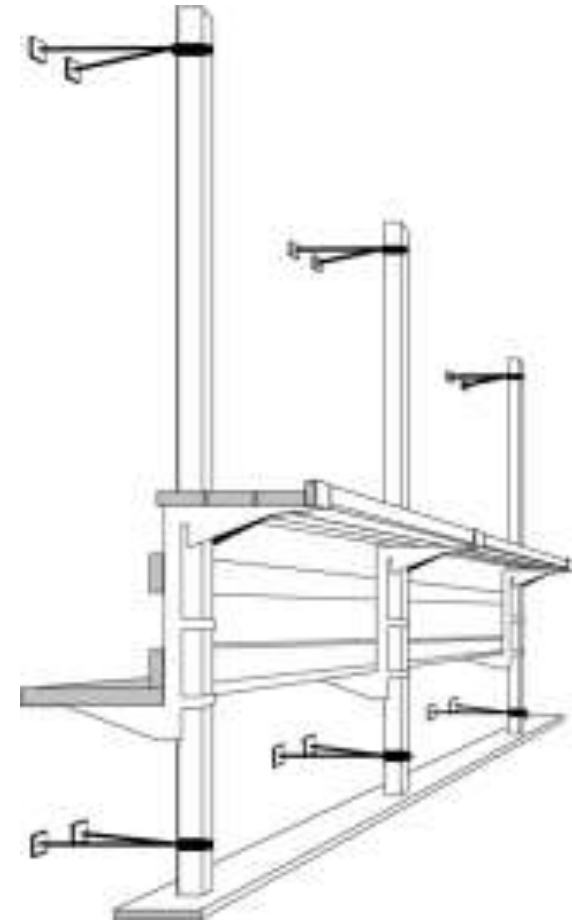

Platform

Plataforma



DANGER PELIGRO

Electrical hazards



Peligros eléctricos

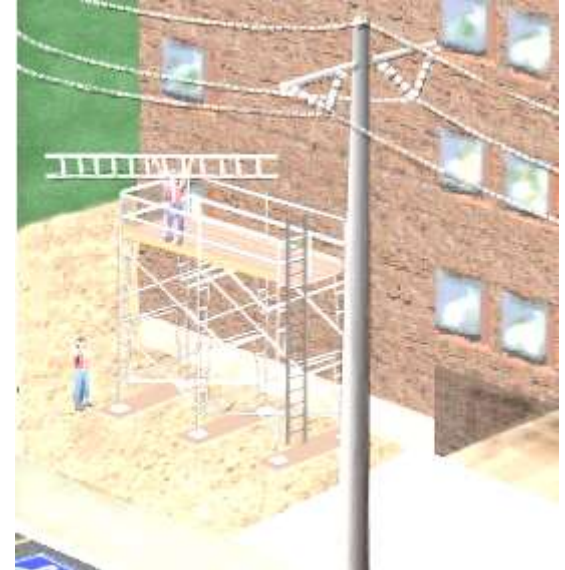

Supported scaffolds

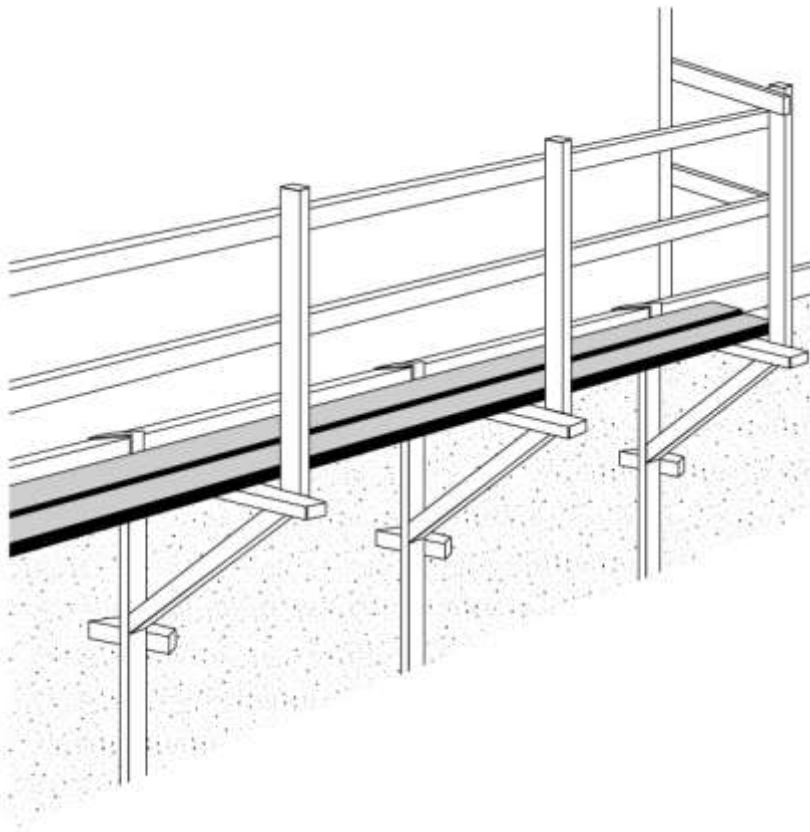

Andamios soportados

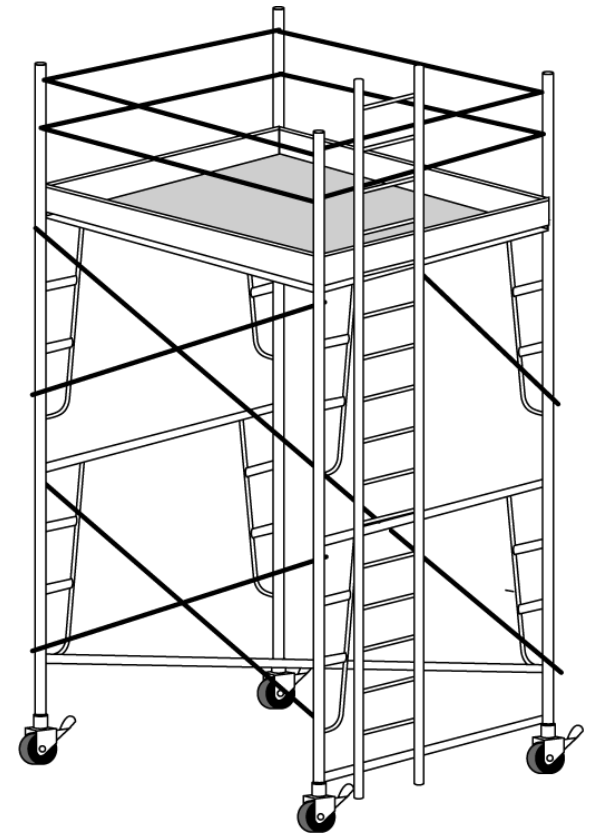

Supported scaffolds

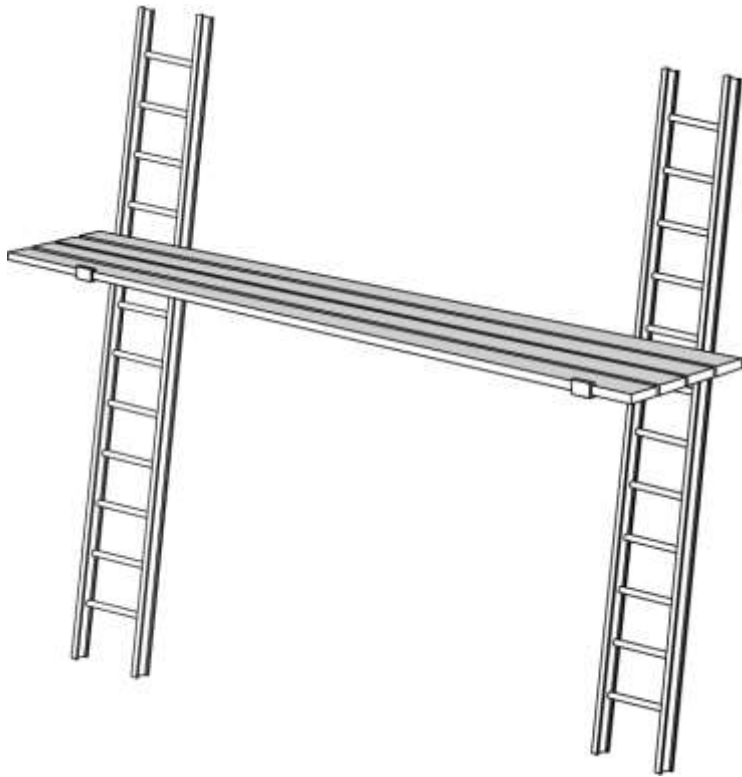

Andamios soportados

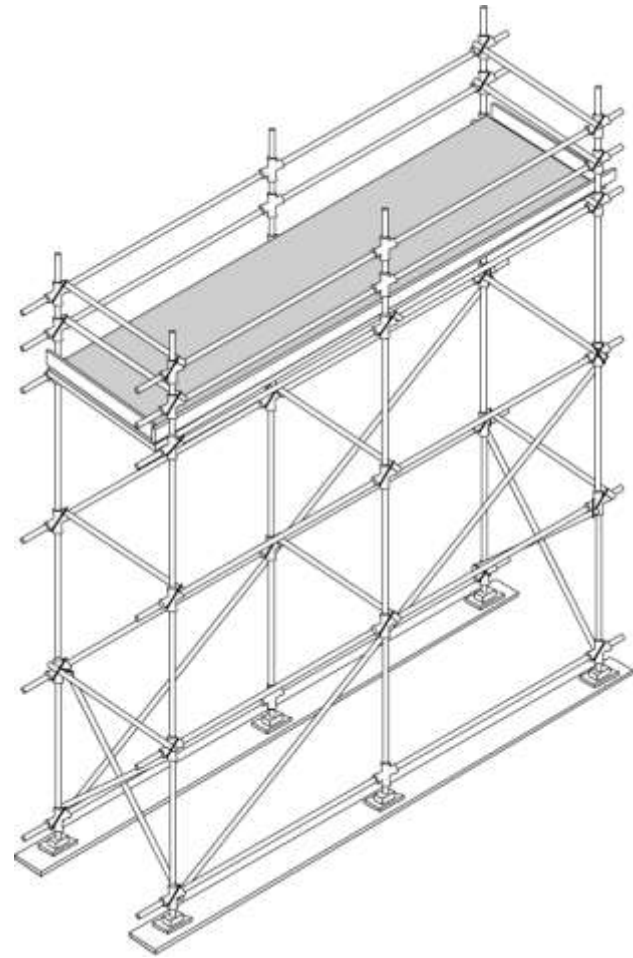

Supported scaffolds

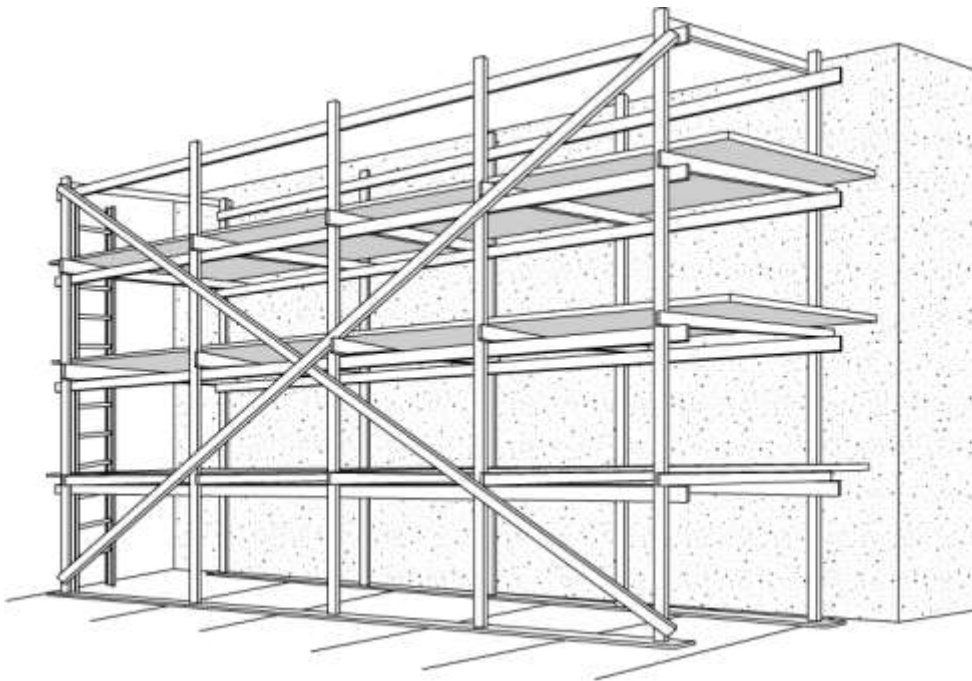

Andamios soportados

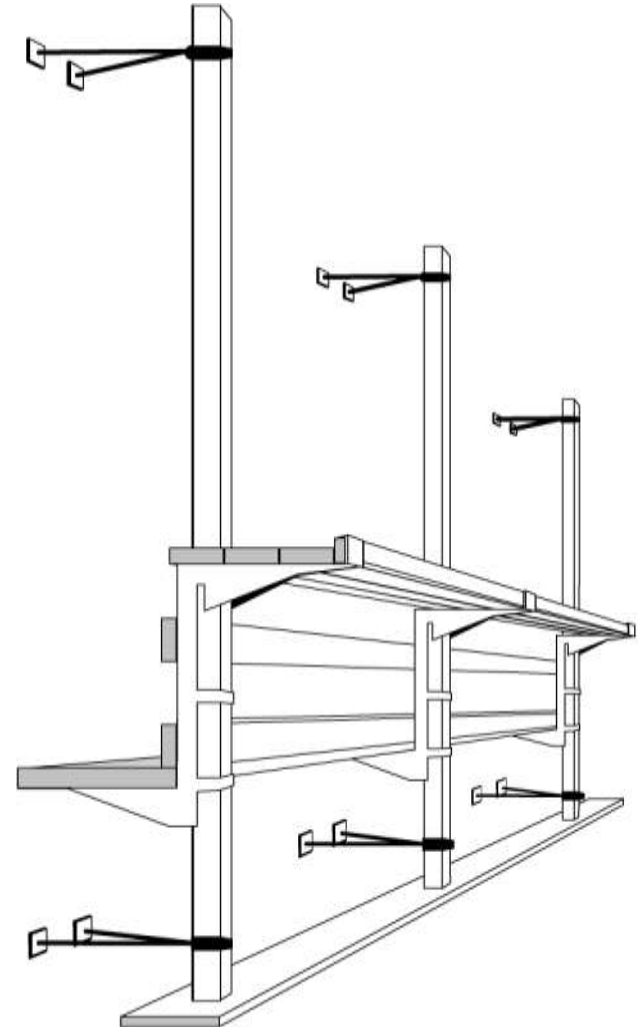

Suspended scaffolds

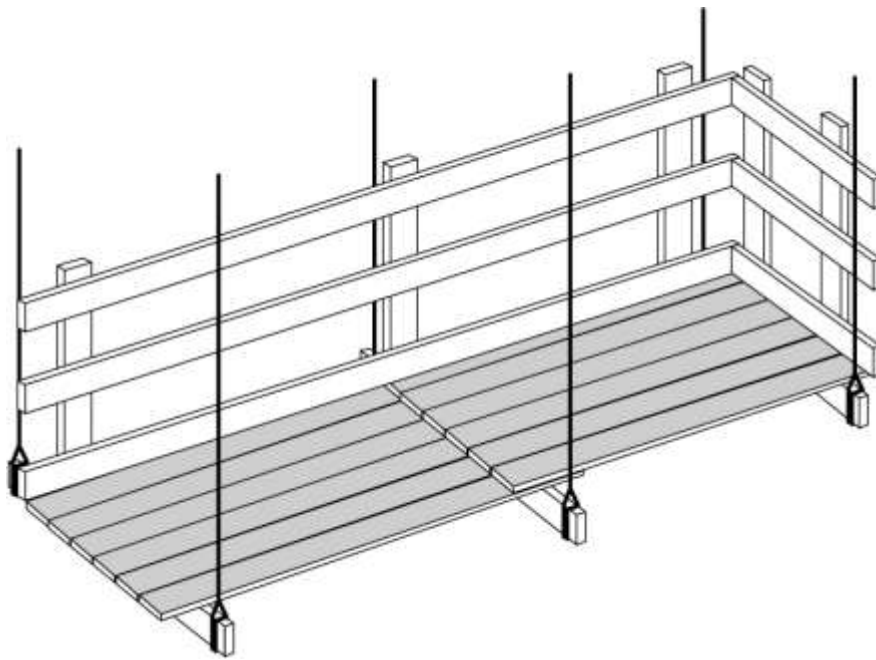

Andamios suspendidos

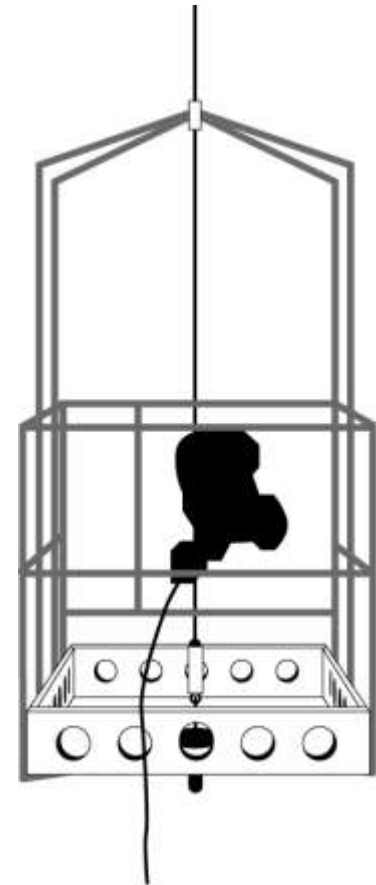

Suspended scaffolds

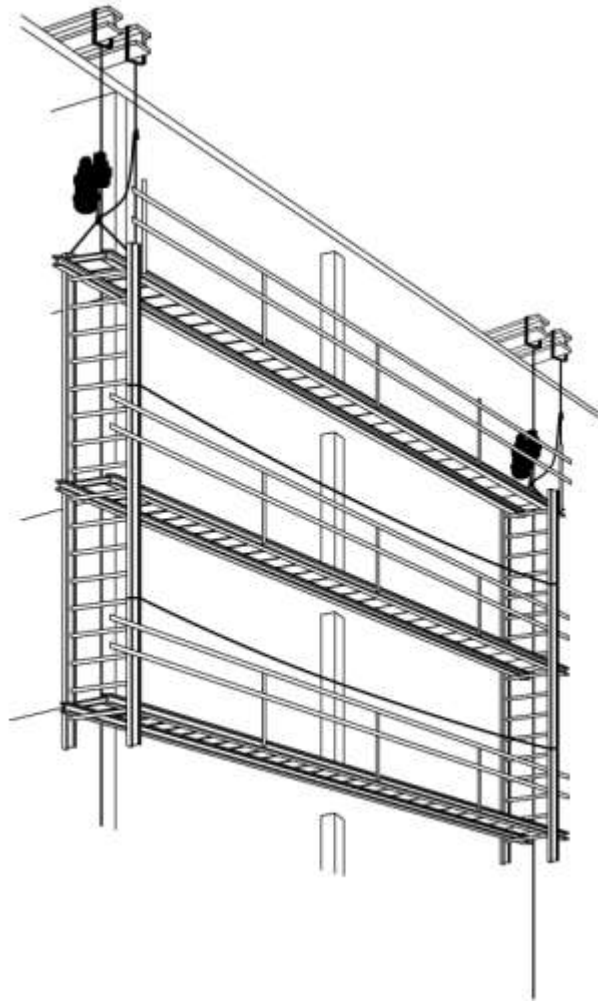

Andamios suspendidos

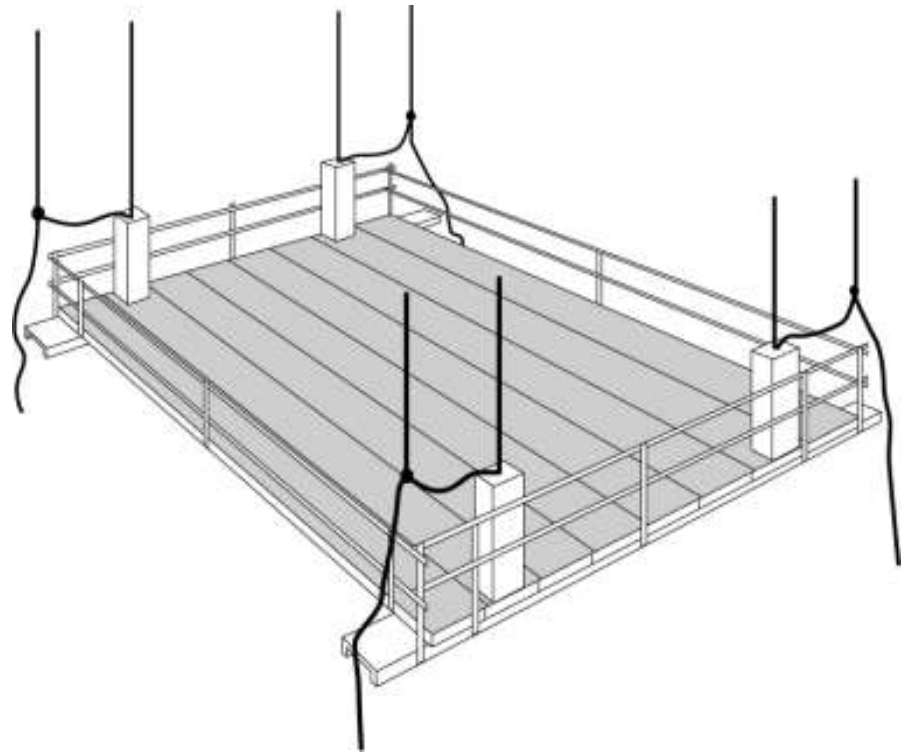

Suspended scaffolds

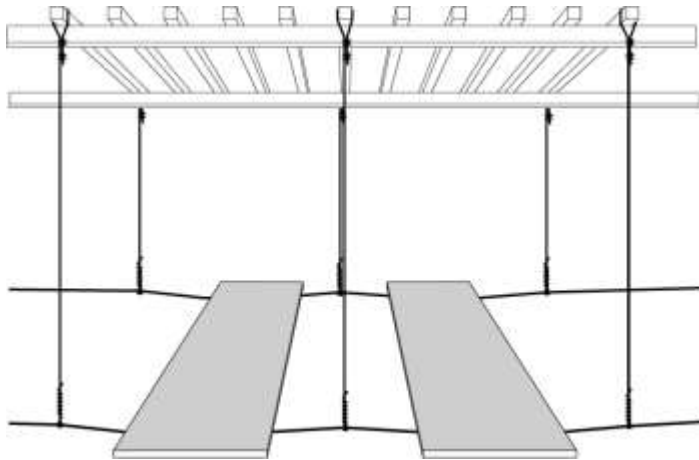

Andamios suspendidos

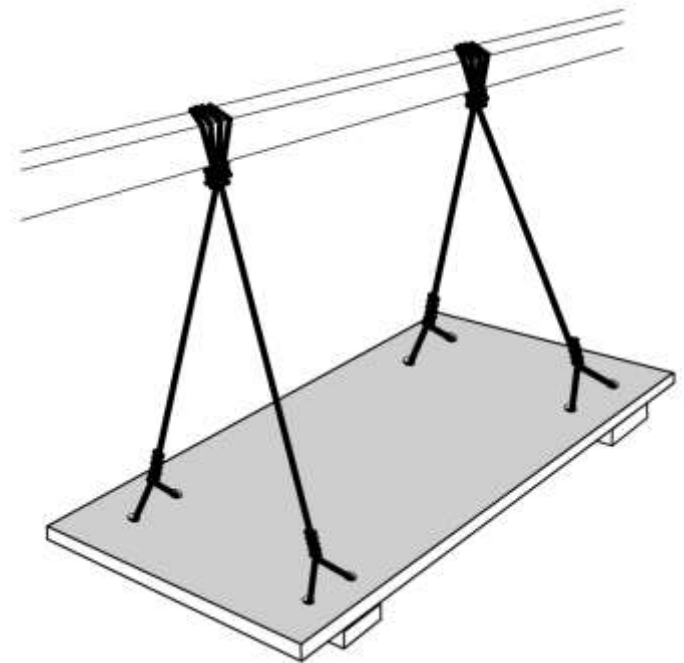

Thank you!

¡Gracias!